

PRODUCT DATA SHEET

ISPKWDIUC Sensor

Intrinsically Safe Underwater Sensor



DESCRIPTION AND FEATURES

The ISPKWDIUC is a wideband acoustic emission sensor with an integral cable. It is designed to meet the intrinsic safety (IS) requirements and can operate in underwater conditions. The sensor features a 26 dB low power, low noise preamplifier that can drive up to 200 meters of cable. The special polymer coatings on the sensor along with an integral waterproof cable make it 100% insulated and non-conductive. The sensor can be used to depths of 1000 psi.

APPLICATIONS

The sensor can be readily used for structural health monitoring in environments requiring intrinsic safety. It can be used for the monitoring of structures like pipelines, pressure vessels and storage tanks in petroleum refineries, chemical plants and offshore platforms.

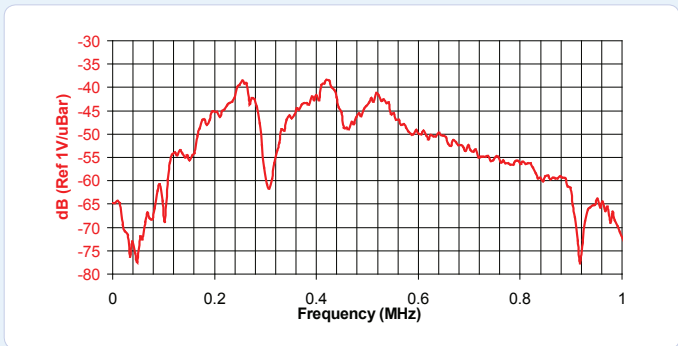
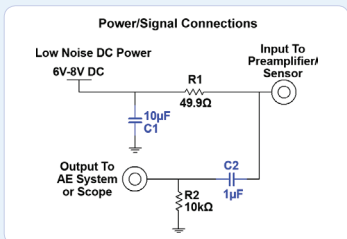
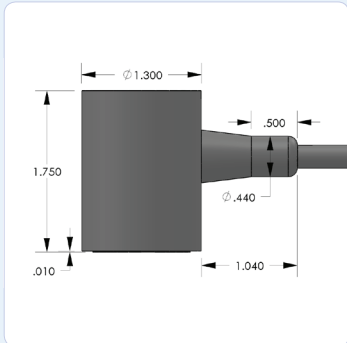

OPERATING SPECIFICATIONS

Dynamic

Peak Sensitivity, Ref V/(m/s).....	80 dB
Peak Sensitivity, Ref V/µbar.....	-38 dB
Operating Frequency Range.....	100-800 kHz
Resonant Frequency, Ref V/(m/s).....	125 kHz
Resonant Frequency, Ref V/µbar.....	530 kHz
Directionality.....	+/-1.5 dB

Environmental

Temperature Range.....	-55° to 70°C
Shock Limit.....	500 g
Completely enclosed crystal for RFI/EMI immunity	

Physical

Dimensions.....	1.31"OD X 1.75"H
	33 mm OD X 45 mm H
Weight.....	.98 grams
Case Material.....	Stainless Steel/Epoxy
Face Material.....	Ceramic
Connector.....	BNC on integral cable
Connector Locations.....	Side

Electrical

Gain.....	26 dB
Preamp DC power.....	5-7 V
Grounding.....	Isolated from mounting surface
Noise level at input.....	<3 µV
Preamplifier dynamic range.....	>87 dB
Preamplifier impedance.....	50 ohm

Certifications

Ex ia IIC T6, -55°C ≤ Ta ≤ 70°C
Ex ia IIIC T85°C, -55°C ≤ Ta ≤ 70°C

ORDERING INFORMATION AND ACCESSORIES

ISPKWDIUC.....	ISPKWDIUC
Cable (specify length in 'XX' m).....	XX
IS Zener Barrier/Preamplifier Interface.....	1281

Sensors include

NIST Calibration Certificate & Warranty



WORLDWIDE HEADQUARTERS:
195 Clarksville Rd •
Princeton Jct, NJ 08550 • USA
T: +1.609.716.4000 • F: +1.609.716.0706
E-MAIL: sales.systems@mistrasgroup.com

CANADA T: +1.403.556.1350
CHINA T: +86.10.5877.3672
FRANCE T: +331.498.26040
GERMANY T: +49.211.730940
GREECE T: +30.210.2846.801

HOLLAND T: +31.010.245.0325
INDIA T: +91.22.2586.2444
JAPAN T: +81.33.498.3570
MIDDLE EAST T: +44(0)1954.231.612
RUSSIA T: +7495.789.4549

SCANDINAVIA T: +46(0)31.252040
S. AMERICA T: +55.11.3082.5111
UK T: +44(0)1954.231.612