

PRODUCT DATA SHEET

PKWDI Sensor

Wideband Low Power Integral Pre-amplifier Resonant Sensor

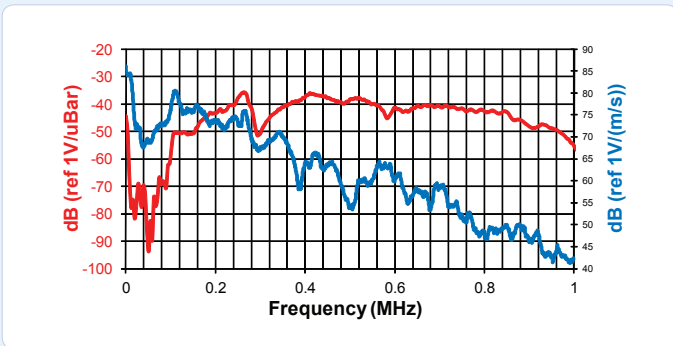
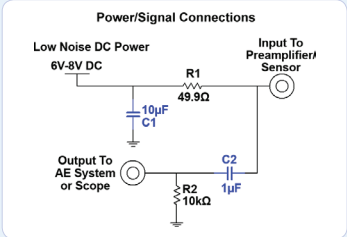
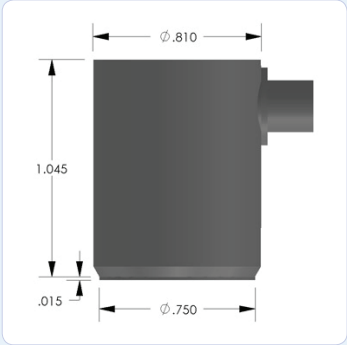
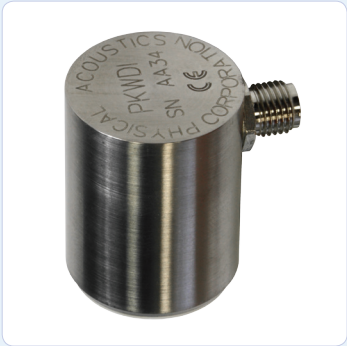

DESCRIPTION AND FEATURES

The PKWDI sensor is a wideband frequency, acoustic emission sensor with an integral, ultra low noise, low power, filtered, 26dB preamplifier, which can drive up to 200 meters of cable. This sensor represents an improvement in both noise and low power consumption performance, with noise level below 3 μV and power consumption of 25 mW. The PKWDI features a strong stainless steel, integrated body structure.

The integrated Auto Sensor Test (AST*) capability allows these sensors to pulse as well as receive. This feature lets you verify the sensor coupling and performance at any time before, during or after the test.

APPLICATIONS

The PKWDI sensor has been designed to be used with the Pocket AE, a small handheld AE system, or with the Sensor Highway II, an outdoor rated, on-line monitoring system.

OPERATING SPECIFICATIONS

Dynamic

Peak Sensitivity, Ref V/(m/s).....	80 dB
Peak Sensitivity, Ref V/μbar.....	-34 dB
Operating Frequency Range.....	200-850 KHz
Resonant Frequency, Ref V/(m/s).....	270 dB
Resonant Frequency, Ref V/μbar.....	110 KHz
Directionality.....	+/- 1.5 dB

Environmental

Temperature Range.....	-35 to 80°C
Shock Limit.....	500 g
Completely enclosed crystal for RFI/EMI immunity	

Physical

Dimensions.....	0.812"OD X 1.07"H
	20.6 mm OD X 27 mm H
Weight.....	51 grams
Case Material.....	Stainless steel
Face Material.....	Ceramic
Connector.....	SMA
Connector Locations.....	Side

Electrical

Gain.....	26 dB
Power Requirements.....	4 to 7 VDC @ 5 mA
Operating/Max Current.....	5/35 mA
Noise Level (RMS RTI).....	< 3 μV

ORDERING INFORMATION AND ACCESSORIES

PKWDI..... PKWDI
 Cable (specify length in 'XX' m at end of PN).....
 1234-SMA/BNC-X
 Magnetic Hold-Down..... MHPK15I
 Amplifier Subsystem..... AE2A, AE5A
 Other IS Sensors are available with various resonant frequencies.

Sensors include

NIST Calibration Certificate & Warranty



WORLDWIDE HEADQUARTERS:
 195 Clarksville Rd •
 Princeton Jct, NJ 08550 • USA
 T: +1.609.716.4000 • F: +1.609.716.0706
 E-MAIL: sales.systems@mistrasgroup.com

CANADA T: +1.403.556.1350
CHINA T: +86.10.5877.3631
FRANCE T: +331.498.26040
GERMANY T: +49.040.2000.4025
GREECE T: +30.210.2846.801-4

HOLLAND T: +31.010.245.0325
INDIA T: +91.22.2586.2444
JAPAN T: +81.33.498.3570
MALAYSIA T: +60.9.517.3788
MIDDLE EAST T: +973.17.729.356

RUSSIA T: +7495.789.4549
SCANDINAVIA T: +46(0)31.252040
S. AMERICA T: +55.11.3082.5111
UK T: +44(0)1954.231.612