

PRODUCT DATA SHEET

ISR3 Sensor

Intrinsically Safe Sensor

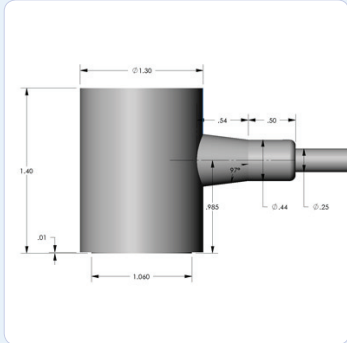

DESCRIPTION AND FEATURES

The ISR3 sensor was designed specially to meet Intrinsic Safety (IS) and IP65 environmental requirements. Certified as Intrinsically Safe (IS) for use with our 1276-2 IS preamplifier and 1276-1 and 1278 IS ASL-C subsystem, this sensor has a thicker ceramic wear-plate and an epoxy coating completely covering the sensor and cable exit. An IS voltage protection circuit is built into the sensor.

It has an integrated one-meter long differential cable with extruded TPE jacket and a pigtail for connecting into a 1276 or 1278 IS Preamplifier or Subsystem. The sensor has similar frequency response as the R3 sensor. Its maximum operating temperature is 125°C.

APPLICATIONS

This sensor is normally selected for structural health monitoring of large-scale concrete structures, geologic structures and for pipeline leak detection applications where large distances between sensors is required, where there is little acoustic background noise and where intrinsically safe sensors and instrumentation are required.

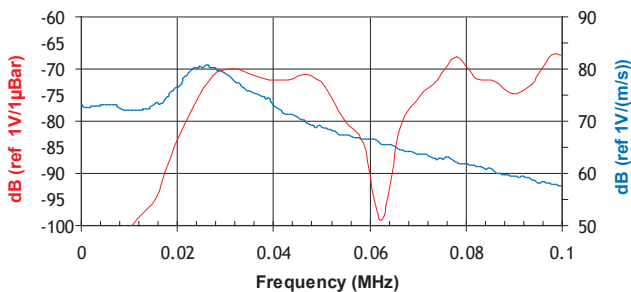

OPERATING SPECIFICATIONS

Dynamic

Peak Sensitivity, Ref V/(m/s)..... 8 dB
Peak Sensitivity, Ref V/μbar..... -63 dB
Operating Frequency Range..... 10-50 KHz
Resonant Frequency, Ref V/μbar..... 29 KHz
Directionality..... +/- 1.5 dB

Environmental

Temperature Range..... -45 to 125°C
Shock Limit..... 1,000 g
Waterproof..... IP66
Completely enclosed crystal for RFI/EMI immunity

Physical

Dimensions..... 1.32"OD X 1.42"H
..... 32 mm OD X 36 mm H
Weight..... 50 grams with 1 meter cable
Case Material..... Stainless steel/Epoxy
Face Material..... Ceramic
Connector..... Pigtail
Connector Locations..... Side
Seal..... Epoxy
Sensor to Preamp Cable (1 meter)..... Integral

Certifications

ATEX Certified, II1, GD, EEx, ia, IIC T4

ORDERING INFORMATION AND ACCESSORIES

ISR3..... ISR3
Pre-amplifier..... 1276-2
ASL-4-20 ma Subsystem..... 1276-1
Preamp to System Cable (specify length in 'm')..... 1276C
IS Zener Barrier..... 1276B
Other IS Sensors are available with various resonant frequencies.

Sensors include

NIST Calibration Certificate & Warranty



WORLDWIDE HEADQUARTERS:
195 Clarksville Rd •
Princeton Jct, NJ 08550 • USA
T: +1.609.716.4000 • F: +1.609.716.0706
E-MAIL: sales.systems@mistrasgroup.com

CANADA T: +1.403.556.1350
CHINA T: +86.10.5877.3631
FRANCE T: +331.498.26040
GERMANY T: +49.040.2000.4025
GREECE T: +30.210.2846.801-4

HOLLAND T: +31.010.245.0325
INDIA T: +91.22.2586.2444
JAPAN T: +81.33.498.3570
MALAYSIA T: +60.9.517.3788
MIDDLE EAST T: +973.17.729.356

RUSSIA T: +7495.789.4549
SCANDINAVIA T: +46(0)31.252040
S. AMERICA T: +55.11.3082.5111
UK T: +44(0)1954.231.612