

PRODUCT DATA SHEET

Micro30 Sensor

Medium Frequency Miniature Sensor

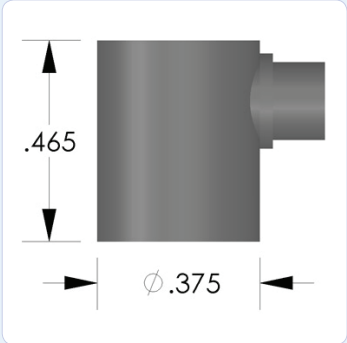

DESCRIPTION AND FEATURES

Micro30 sensor has a good frequency response over the range of 150 – 400 kHz. It has good sensitivity to AE signals even in presence of high background noise. Its small size and good bandwidth makes the sensor an ideal candidate for applications that have size and weight constraints on the sensors. The sensor features a small diameter, microdot connector exiting from the side of the sensor.

APPLICATIONS

The high sensitivity and bandwidth makes them ideal for structural health monitoring of critical structures like aircrafts, storage tanks etc. Typical applications include monitoring for fatigue and corrosion cracking in metals, delaminations and fiber breakage in composites. It can be mounted easily using epoxy.

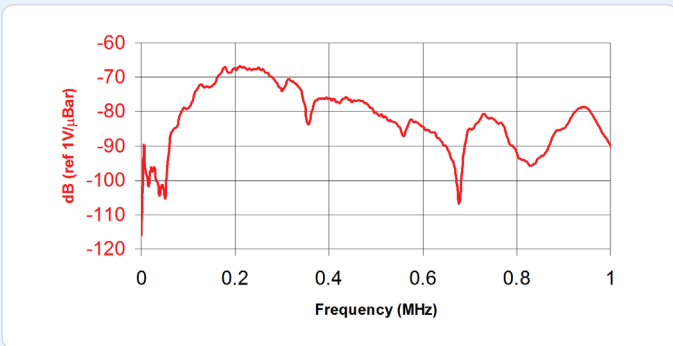

OPERATING SPECIFICATIONS

Dynamic

Peak Sensitivity, Ref V/(m/s).....	65 dB
Peak Sensitivity, Ref V/μbar.....	-67.5 dB
Operating Frequency Range.....	150-400 KHz
Resonant Frequency, Ref V/(m/s).....	125 KHz
Resonant Frequency, Ref V/μbar.....	225 KHz
Directionality.....	+/-1.5 dB

Environmental

Temperature Range.....	-65 to 177°C
Shock Limit.....	500 g
Completely enclosed crystal for RFI/EMI immunity	

Physical

Dimensions.....	0.4"OD X 0.5"H
	10 mm OD X 12 mm H
Weight.....	5 grams
Case Material.....	Stainless steel
Face Material.....	Ceramic
Connector.....	Microdot
Connector Locations.....	Side

ORDERING INFORMATION AND ACCESSORIES

Micro30.....	Micro30
Cable (specify cable length in 'm').....	1232-1
Preamplifier.....	0/2/4, 2/4/6
Preamp to System Cable (specify length in 'm').....	1234-X
Amplifier Subsystems.....	AE2A, AE5A

Sensors include

NIST Calibration Certificate & Warranty



WORLDWIDE HEADQUARTERS:
195 Clarksville Rd •
Princeton Jct, NJ 08550 • USA
T: +1.609.716.4000 • F: +1.609.716.0706
E-MAIL: sales.systems@mistrasgroup.com

CANADA T: +1.403.556.1350
CHINA T: +86.10.5877.3631
FRANCE T: +331.498.26040
GERMANY T: +49.040.2000.4025
GREECE T: +30.210.2846.801-4

HOLLAND T: +31.010.245.0325
INDIA T: +91.22.2586.2444
JAPAN T: +81.33.498.3570
MALAYSIA T: +60.9.517.3788
MIDDLE EAST T: +973.17.729.356

RUSSIA T: +7495.789.4549
SCANDINAVIA T: +46(0)31.252040
S. AMERICA T: +55.11.3082.5111
UK T: +44(0)1954.231.612