

AE2A & AE5A: Low Noise, High-Performance and Wide Bandwidth Amplifier Systems for Acoustic Emission Preamplifiers and Sensors



PAC's **AE2A/AE5A** second generation series of AE Amplifiers are small, high-performance Acoustic Emission (AE) systems that amplify and filter an incoming AE signal either directly from an AE sensor or from an external preamplifier. The resulting high-frequency AE analog signal output can be connected to a variety of external monitoring and data acquisition instruments. The AE output is most commonly connected to an analog or digital oscilloscope in order to view a cause and response relationship. The model AE2A covers the entire **traditional** AE bandwidth up to 2 MHz, while the model AE5A covers the **extended** AE frequency up to 5 MHz.

Featuring variable gain, **low noise** and an optional variety of high pass, low pass and band pass filters, this device has a plug-in filter to optimize sensor selectivity and noise rejection. An optional internal preamplifier is available for situations where the sensor cable is short (<2m), to eliminate the need for external preamplifiers. Also available is an RMS output option. This option provides an additional

analog AE output signal, which is converted to an RMS representation, with selectable **time constants** of 50ms and 500ms, and is user selectable. In cases where an external preamplifier is needed, the AE2A and AE5A are fully compatible with PAC's line of preamplifiers such as the 1220A, PAC 2/4/6, 0/2/4, 4/6, ILXXS, ILXXD, as well as PAC's line of integral preamplifier AE sensors such as R6I, R15I, R30I, R50I and WDI.

AE2A/AE5A Features:

- Pluggable filter modules with the capability of using high pass, bandpass or low pass filter to vary the bandwidth of the detected AE signal. PAC stocks many types of filters and also has the capability of supplying custom user-requested filters with fast turnaround
- Capability of interfacing and powering PAC 1220A series preamplifiers, 2/4/6, 0/2/4, 4/6, In-Line series preamplifiers (e.g. IL-40D, IL-40S) and integral preamplifier sensors) through a single coax cable
- AE output is can drive an analog signal source of 50 ohms

Options:

- Options include an internal 40 dB preamplifier
- RMS analog signal processing option with 50 and 500 millisecond time constants

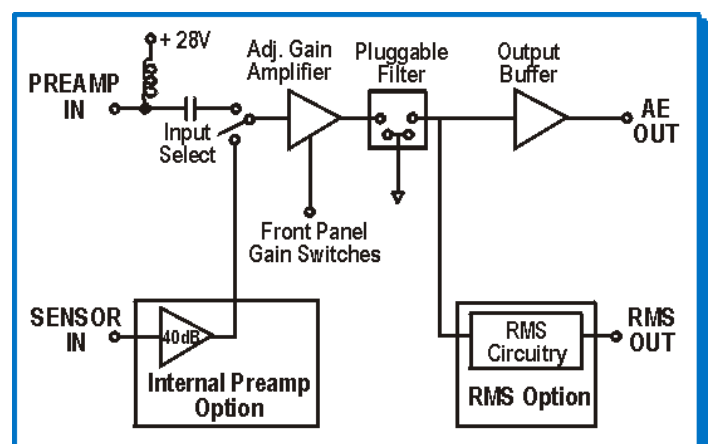

AE Signal Processing Specifications:

Specification Description	AE2A	AE5A
• Dynamic Range	93 dB standard	
• Bandwidth	3 kHz - 2 MHz	10 kHz - 5 MHz
• Noise	4 μ Vrms RTI max	6 μ Vrms RTI max
• AE Input (standard for preamplifier (100 ma current limit))	50 W AE input with integral 28 VDC power	
• AE Signal Output	17 Vp-p into 50W load (20 Vp-p burst)	
• Internal Filtering	Via PAC 1220 Series plug-in filters; User specified	
• Internal Gain	0 - 61 dB (3 dB steps)	0 - 41 dB (3 dB steps)
Options		
• RMS Output (with 2 selectable time constants, 50 & 500 milliseconds via front panel switch)	0 - 7 Volts	
• Optional Internal Preamplifier	40 dB gain (Bandwidth same as above for specific unit AE2A or AE5A)	
• Optional Switched Sensor Input (comes with preamplifier option)	10 kW/20 pf load to optional internal preamplifier	

Electrical Specifications:

- Power: 110 or 220 VAC 50/60Hz (field selectable)
- Operating Current: <1 amp AC (at 110 VAC)
<0.5 amp AC (at 240 VAC)
- Fuse Requirements: Uses standard 5 x 20 mm fuses
Uses 0.5 amp (for 220 - 250 VAC operation)
Uses 1.0 amp (for 100 - 120 VAC operation)

Environmental Specifications:

- Temperature: - 0 °C to + 50 °C (+32 °F to 122 °F)

Physical Specifications:

- Dimensions: 6" (L) x 5½" (W) x 2½" (H)
15.24cm x 13.97cm x 6.35cm
- Weight: 2.7 lbs. (1.2 kg)

CE Mark Compliance:

- Electrical Safety Stds: Meets EN60950 (IEC-950)
- EMC Emission Stds: Meets EN55011, EN55022
- EMC Immunity Stds: Meets EN50082, IEC-1000-4-2, IEC-1000-4-3, IEC-1000-4-4



**For more information about the
AE2A/AE5A Amplifier Systems
Call (609) 716-4000 or e-mail us at sales@pacndt.com**

**For information on PAC products and services,
visit our web site at: www.pacndt.com**



HQTS: 195 Clarksville Road • Princeton Junction, NJ 08550 • Phone: (609) 716-4000 • Fax: (609) 716-0706
 • email: sales@pacndt.com • Internet: www.pacndt.com **Subsidiaries:** • Cambridge (44) 1954-231612
 • Paris (33) (1) 4982-6040 • Tokyo (81) (3) 3498-3570 • São Paulo (55) (11) 3082-5111 • Athens (30) (210) 284-6801
 • Moscow (7095) 789-45-49 • Beijing (86) (10) 8497-3570 • Buenos Aires (54) (11) 4345-0400 • Wolfegg
 (49) (75) 272312 • Rotterdam (31) (10) 245 0325 **Representatives:** Worldwide.

Sound Technology for Safety & the Environment